



TECHNICAL INFORMATION

PERFORMANCE CHARACTERISTICS OF MULTILAYER GLASS DIELECTRIC CAPACITORS

by Ron Demcko
AVX Corporation
Raleigh, NC

Abstract:

Glass dielectric capacitors exhibit several key performance parameters critical to high performance circuitry. This technical paper is a summary of specialized tests performed on AVX glass capacitors to demonstrate their in-circuit characteristics.

PERFORMANCE CHARACTERISTICS OF MULTILAYER GLASS DIELECTRIC CAPACITORS

by Ron Demcko
AVX Corporation
Raleigh, NC

Introduction

Glass Dielectric Capacitor Construction

AVX Glass dielectric capacitors offer the end user the highest performance and reliability features available in the capacitor industry.

The construction of Glass capacitors is straightforward. There are only three elements: glass dielectric and case, aluminum electrodes, wire terminals. (Radial capacitors have a molded case.) The capacitors are made in a multilayer fashion (as shown below).

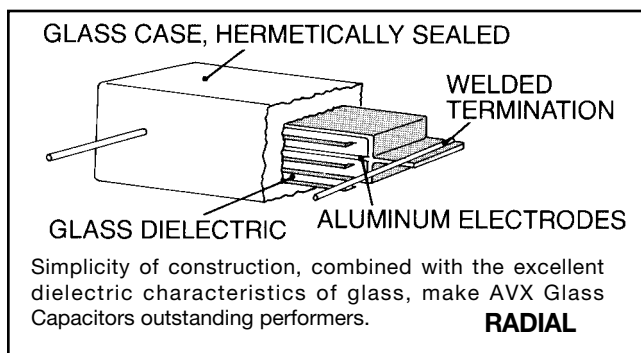
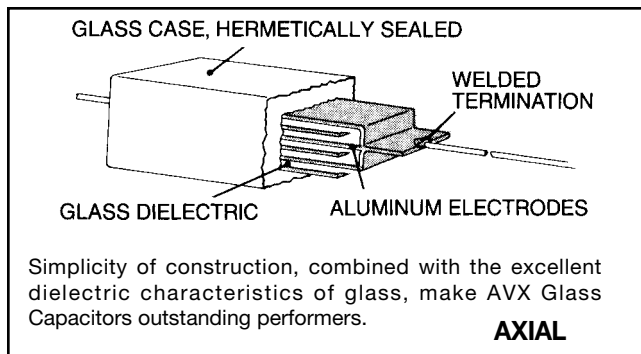

AVX performs a 100% inspection on each capacitor checking: capacitance value and tolerance, rated voltage, and hermetic seal (axials). The combination of tight quality control, simplicity of design, and a superior material system means that AVX Glass capacitors are close to being the "perfect circuit symbol."

Here is an overview of AVX Glass capacitor features:

High Stability – Low Retraceable Temperature Coefficient (TC)
No Hysteresis
Zero Aging Rate
Zero Piezoelectric Noise

Extremely Low Losses – Stable Q Factor at High Frequencies
Low Dielectric Absorption

Large RF Current Capability

Nuclear Radiation Hardness (Axials)

High Operating Temperature Range (Up to 200°C)

High Shock/Vibration Capability

Excellent High Vacuum Performance

Glass Capacitor Applications

Glass capacitors have traditionally seen widespread usage in military applications with a large number of new designs occurring in the aerospace and high performance commercial sectors. Glass capacitors have applications across the entire spectrum of electronic circuits and their past success on a variety of manned and unmanned space missions continues to fuel interest of the defense and aerospace industries.

The following is a list of general applications where Glass capacitors are currently utilized:

Radiation Hardened Circuitry	Ramp Integrators
Burn in Oven Circuitry +200°C	Voltage Snubbers
High Temperature Circuitry	Transistor Biasing
Galvanometers	Low Temperature Circuitry
Radar Systems	(-150°C)
Modulators	Bridge Reference Capacitors
Gyro Systems	Temperature Sensing Circuitry
R.F. Amplifiers Output Filters	Jet Engine Monitors
Low Noise Receiver Front Ends	Dosimeters
Variable Frequency Oscillators	Space Defense/Satellites
Voltage Controlled Oscillators	Geophysical Sensors
Amplifier Coupling	Porcelain Capacitor Replacements
Impedance Transformation	Medical Monitoring Circuitry
Networks	Missile Systems and Avionic
PLL Circuitry	Circuitry
Sample and Hold Capacitor	

Application assistance on any specific circuitry is available from the Raleigh, NC applications hotline: (919) 878-6224.

Glass Capacitor Electrical Characteristics

Capacitance Stability

Glass capacitors exhibit excellent stability characteristics as a result of their unique material system.

The temperature coefficient for Glass capacitors (stated in linear approximation form) is 140±25ppm/°C. However,

the actual temperature coefficient is shown below (see Figure 1). Furthermore, the temperature coefficient of all Glass capacitors will retrace to within $\pm 5\text{ppm}/^\circ\text{C}$ of the TC curve without exhibiting hysteresis. The capacitance change vs. temperature of Glass capacitors is shown in Figure 2.

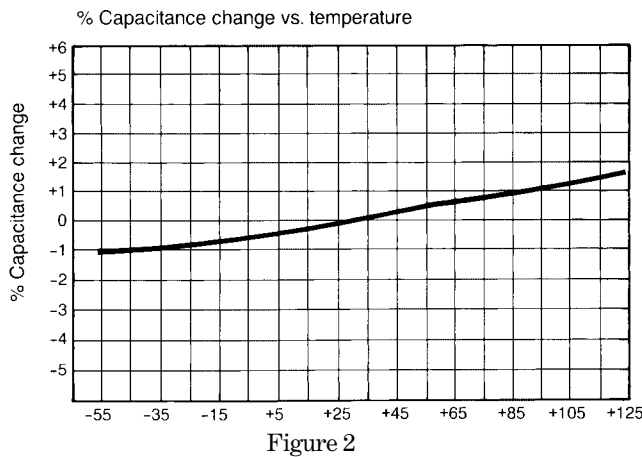
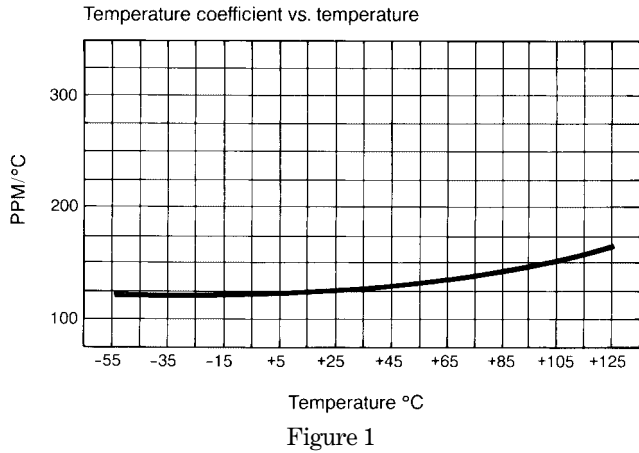

Long Term Stability

Numerous five year "drift tests" were conducted on standard CY Glass capacitors which indicate Glass capacitors have zero aging rate. The components under test were read for capacitance immediately after production. They were then stored under normal room conditions and reread for capacitance value five years later. The maximum positive drift was 0.07% of initial capacitance value and the maximum negative drift was 0.09%.

Long term stability investigations were also performed under load life test conditions. The results of one such test are as follows:

Table I
Long Term Load Life Data

Style	No. Hours on Test	No. of Pieces	Value and Tolerance (pF)	Max. Cap. Change %	Max. DF %	Min. IR	Min. Q
CY10	39,558	10	120 \pm 10%	.58	.058	10 ¹³	1691
CY15	47,597	10	430 \pm 10%	.63	.042	10 ¹³	2534
CY20	54,815	10	330 \pm 10%	.47	.058	10 ¹²	1112
CY30	54,764	10	5600 \pm 10%	.58	.057	10 ¹²	1566

All Glass capacitors exhibit zero piezoelectric noise and have zero voltage coefficient regardless of age or style.

Loss Characteristics

AVX Glass capacitors exhibit low loss over a wide operating temperature and frequency range. The following graphs describe loss characteristics as a function of temperature, capacitance value/form factor, and frequency.

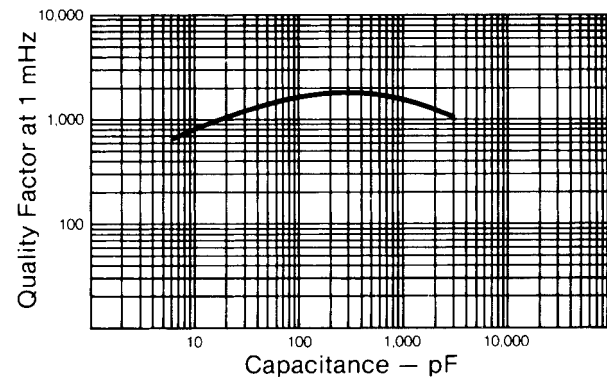
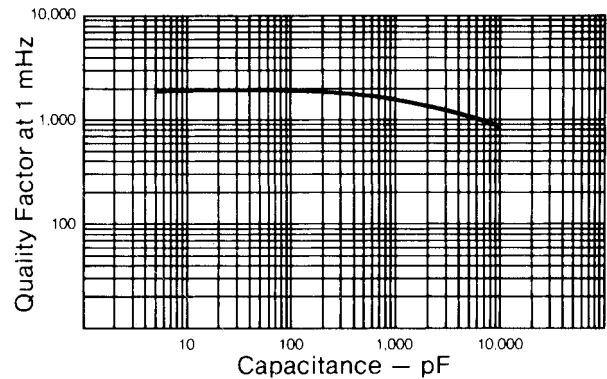
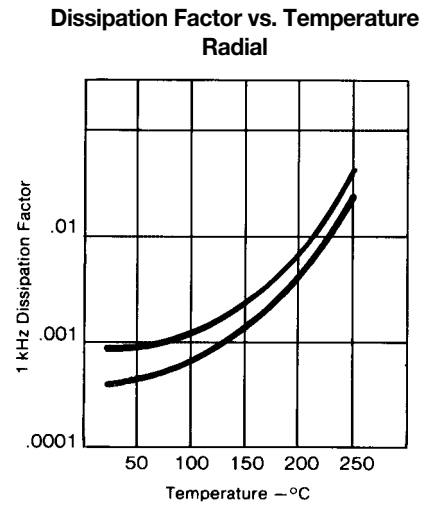

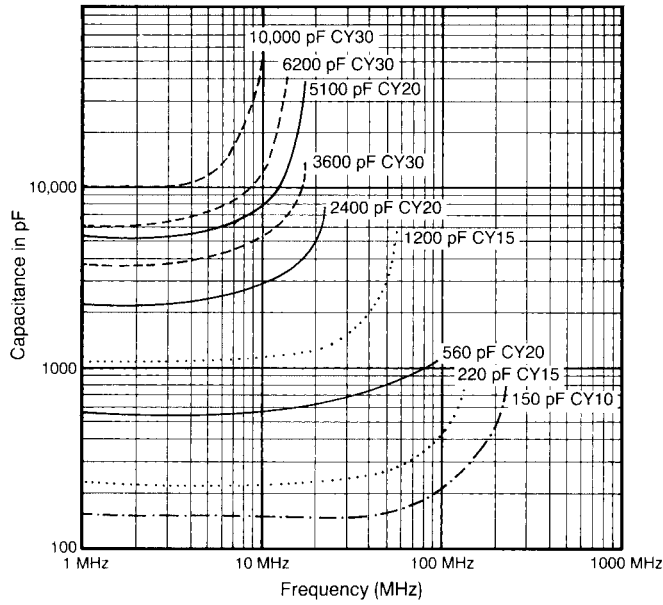

**Capacitance vs. Frequency
Axial**
Figure 6

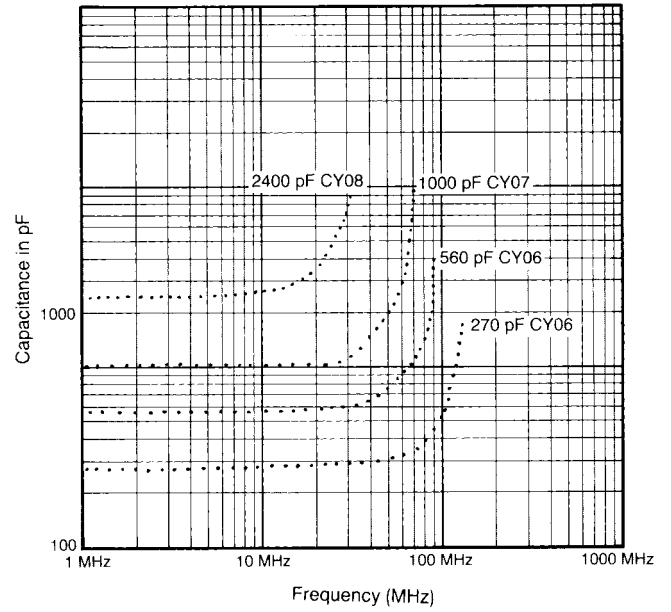

**Capacitance vs. Frequency
Radial**
Figure 9

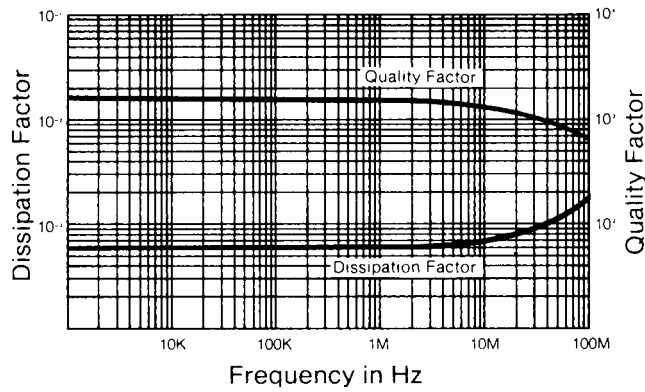

**Quality Factor and Dissipation Factor vs. Frequency
Radial**
Figure 7

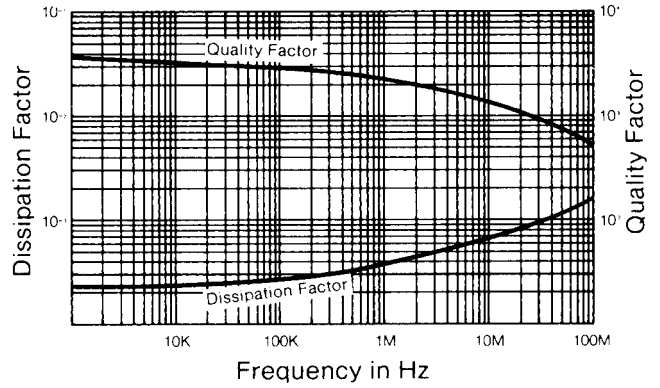

**Quality Factor and Dissipation Factor vs. Frequency
Axial**
Figure 10

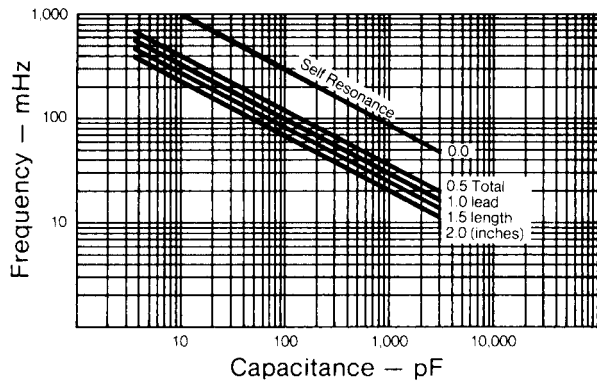

**Resonant Frequency vs. Capacitance
Radial**
Figure 8

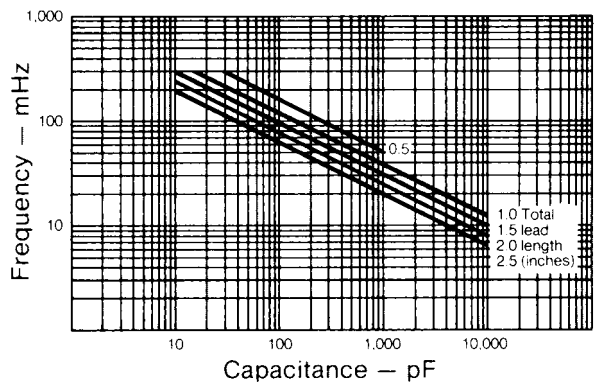

**Resonant Frequency vs. Capacitance
Axial**
Figure 11

Dielectric Absorption

Glass dielectric capacitors have been tested for Dielectric Absorption (DA) characteristics per Military Specification MIL-C-19978 and have shown a consistently low Dielectric Absorption from lot to lot (0.012% is typical). In addition to DA figures which are comparable to polystyrene, glass capacitors exhibit zero aging rate, zero piezoelectric noise, and a $\pm 5\text{ppm}$ TC retraceability regardless of component age. Furthermore, glass capacitors exhibit zero voltage coefficient and low thermal and charge noise figures.

Glass capacitors continue to experience widespread usage in sample and hold current integrators, and in high gain amplifiers as a result of these performance features.

AVX Glass Capacitors – RF Current Applications

AVX Glass dielectric capacitors can handle large Radio Frequency (RF) currents over a wide frequency range. (See following graphs.)

Glass dielectric capacitors have a high Q factor and a low dissipation factor that changes little with frequency and temperature excursions. This coupled with a low, retraceable, extended range temperature coefficient ensures repeatable, reliable performance – regardless of the capacitor's environment.

The large RF currents that glass dielectric capacitors can handle make them ideal for use in modulators, filters, and linear amplifiers.

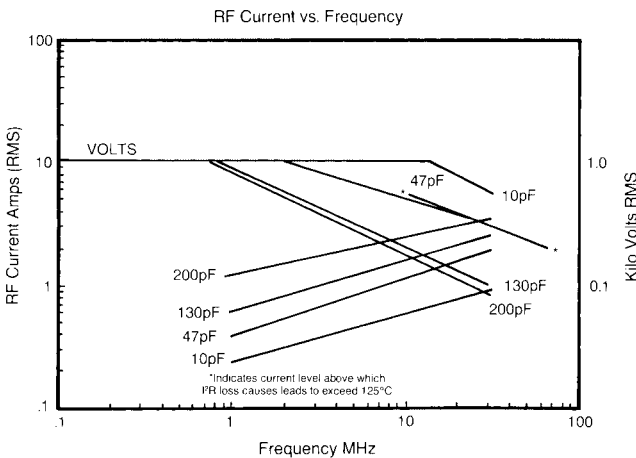

Figure 12

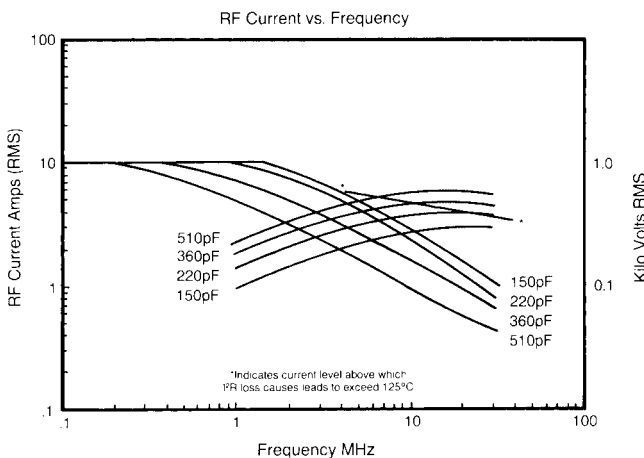

Figure 13

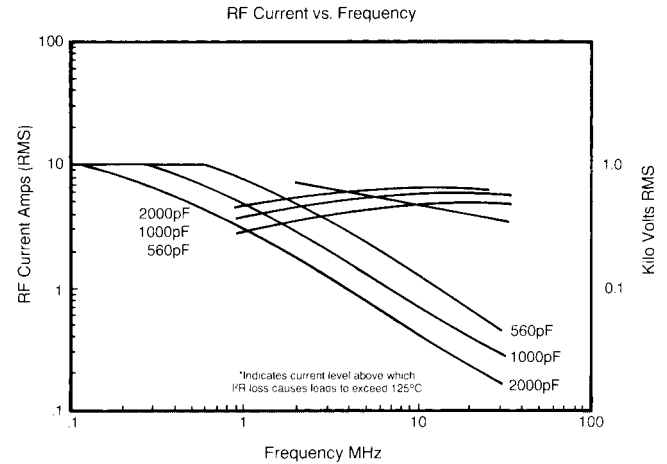

Figure 14

Nuclear Radiation Hardness

AVX axial Glass capacitors are made of inorganic materials and are highly resistant to nuclear radiation, voltage breakdown, and high operating temperatures.

When exposed to a neutron radiation field of 10^{15} fast N/CM² SEC, AVX Glass capacitors were shown to have a transient capacitance increase of between 0.7 to 2.5 percent, while exhibiting a permanent capacitance increase of less than 0.5 percent. AVX Glass capacitors can operate in neutron flux environments 10 to 100 times more intense than other capacitor technologies and experience only minor damage. Furthermore Glass capacitors will not become a toxic hazard when exposed to radiation.

A summary of various capacitor technologies' performance under a neutron radiation field is shown below.

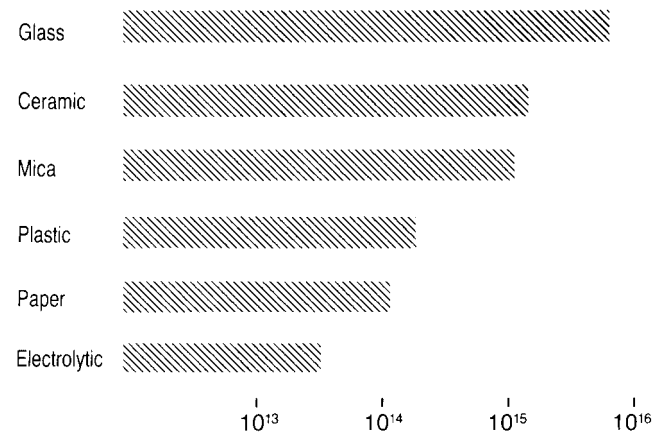

Figure 15

Capacitors ability to operate in neutron field intensity (Flux/cm²)

When exposed to gamma irradiation, Glass capacitors exhibit an extremely small transient and permanent capacitance change and a consistently low dissipation factor with frequency.

The capacitors under test were uniformly exposed to a total dose of 9.6×10^7 rads (H₂O) and measured for capacitance value and dissipation factor across a frequency range of 100Hz to 100kHz before irradiation, immediately after irradiation, 2 hours after irradiation, and 96 hours after irradiation. Results of such testing are as follows:

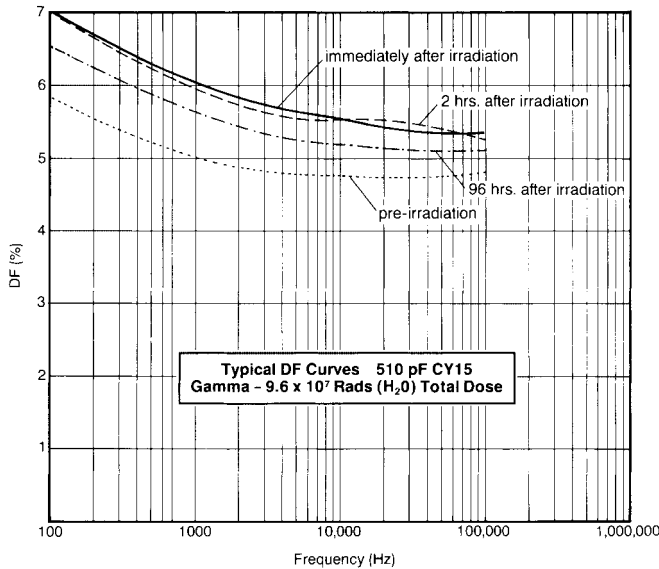

Figure 16

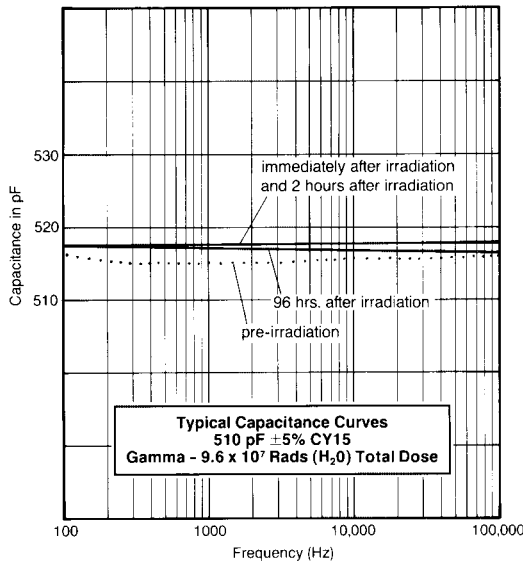

Figure 17

Elevated Temperature (+200°C) Performance

Temperature extremes are the enemy of reliable and long term circuit performance. Elevated Temperature (ET) series of Glass and Miniature Glass-K capacitors are designed to meet these requirements.

After years of research, this wide range capability was achieved by matching and optimizing thermal expansion rates of the materials in Glass capacitor manufacture.

AVX ET series capacitors also provide the same highly reliable characteristics as other AVX Glass capacitors such as nuclear radiation stability, outstanding capacitance retraceability, and rugged, yet simple, construction that eliminates mechanical problems.

- ET Features**
- Available in both Axial and Radial Configurations
 - Radiation Hardened (Axials)
 - Values from 0.5pF to 10,000pF
 - Rugged design and construction

- ET Features con't.**
- "Burned in" versions available - 50 hours, 1500 vdc, 25°C
 - Voltage coefficient = 0
 - Working temperature range - 75°C to +200°C
 - Short term (≤1 hour) exposure to 250°C no performance degradation
 - High Voltage Pulse withstanding capability
 - Low Noise - excellent choice with GaAs circuitry

- Typical Applications**
- Semiconductor Burn-in Ovens
 - Oil Well Logging and Down Hole Instrumentation
 - Geophysical Pressure Probes
 - Remote Antenna Low Noise Amplifiers (LNAs)
 - Radio Frequency (RFD) Output Circuitry
 - Missile and Aerospace Transducers
 - Super Cooled High Speed Logic
 - Cold Low Noise Radar Circuitry
 - Aerospace Solar Array-Systems
 - Cryogenic Sensors

- Standard Operating Characteristics of AVX ET Capacitors**
- Working Temperature Range... -75°C to +200°C, Short Term (≤1 hours) exposure to 250°C with no degradation in performance
 - Voltage Rating... 50 vdc
 - Capacitance Range... 0.5pF to 10,000pF
 - Insulation Resistance... at 25°C > 100,000 megohms at 200°C > 1 x 10⁸ ohms

- Dissipation Factor... at 25°C < 1% at 1kHz at 200°C < 1% at 1kHz
- Life... (200°C, 1000 hour life at rated voltage)
- Post Life Test... Delta C at 25°C < 2% DF at 25°C < 2.5% IR > 10⁸ ohms (Axials) IR > 10⁷ ohms (Radials)

Dissipation Factor vs. Temperature

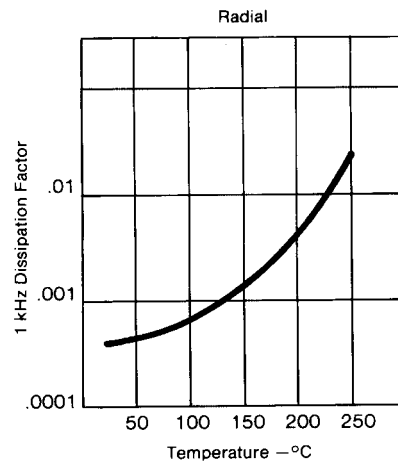

Figure 18

% Capacitance Change vs. Temperature

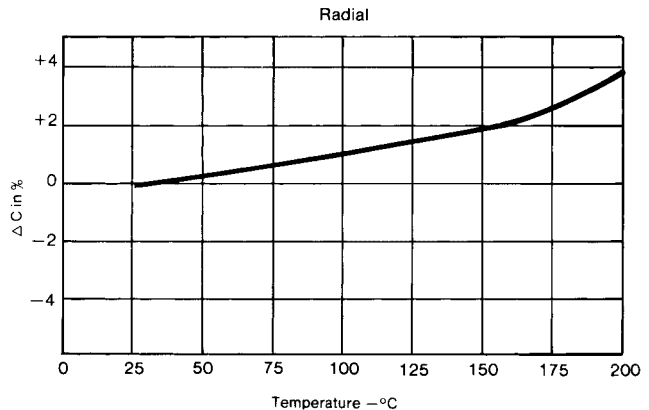
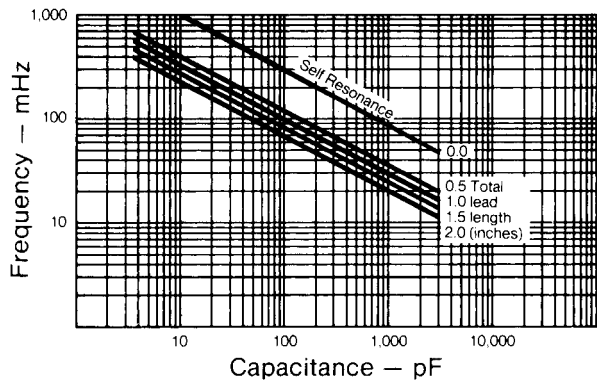

Figure 19



Resonant Frequency vs. Capacitance Radial

Figure 20

Miniature Elevated Temperature (ET) Capacitors

Elevated Temperature (ET) Glass-K capacitors utilize a proprietary Glass-K™ dielectric and are available in three different K factors which correspond to specific stability characteristics and capacitance value ranges. Also, Glass-K™ dielectrics are fused into a compact multilayer monolithic structure and have a transfer molded case. Their stable performance coupled with an excellent frequency response and miniature size make them a natural choice for oil well logging systems, jet engine monitors, semiconductor burn-in ovens, or geophysical probes.

ET Glass-K Features

- Values from 270pF to 100,000pF
- Proprietary Glass-K™ dielectric
- Standard burn-in per M39014
- Working temperature range -75°C to +200°C
- Excellent VHF characteristics

Standard Operating Characteristics of AVX Glass-K ET Capacitors

- Working Temperature Range... -75°C to +200°C
- Voltage Rating... .25 vdc

Capacitance Range

- 270pF to 100,000pF as follows:
 - K250... 270pF to 20,000pF
 - K380... 12,000pF to 39,000pF
 - K888... 22,000pF to 100,000pF

Dissipation Factor

- at 25°C
 - K250... 1.0%
 - K380... 1.5%
 - K888... 3.0%
- at 200°C
 - K250... 1.5%
 - K380... 2.5%
 - K888... 4.0%

Insulation Resistance

- at 25°C... 1 x 10¹¹ Ohms
- at 200°C
 - K250... 10⁸ Ohms
 - K380... 10⁹ Ohms
 - K888... 10⁹ Ohms

Life

- (at 200°C, 250 hour life test at rated voltage) Post test life data as follows:
 - K250... Delta C at 25°C < 1%
DF at 25°C < 4%
IR at 25°C > 1 x 10⁹ Ohms
 - K380... Delta C at 25°C < 2%
DF at 25°C < 2%
IR at 25°C > 1 x 10⁹ Ohms
 - K888... Delta C at 25°C < 4%
DF at 25°C < 8%
IR at 25°C > 1 x 10⁷ Ohms

ET Glass-K™ Series Typical Performance Characteristics

A. Dielectric Type K 250

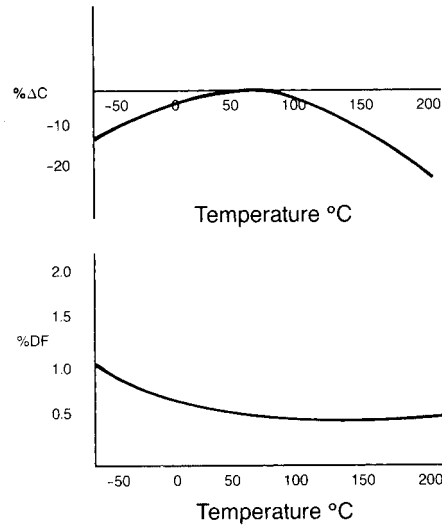

B. Dielectric Type K 380

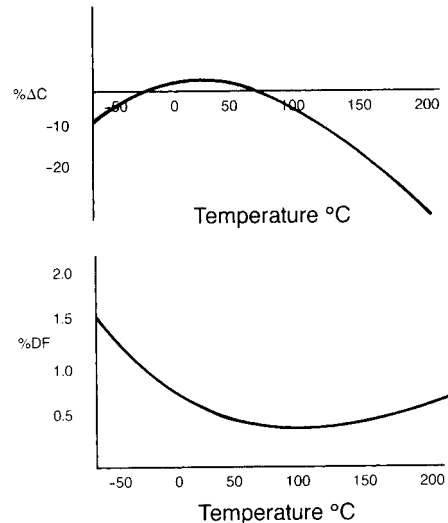

C. Dielectric Type K 888

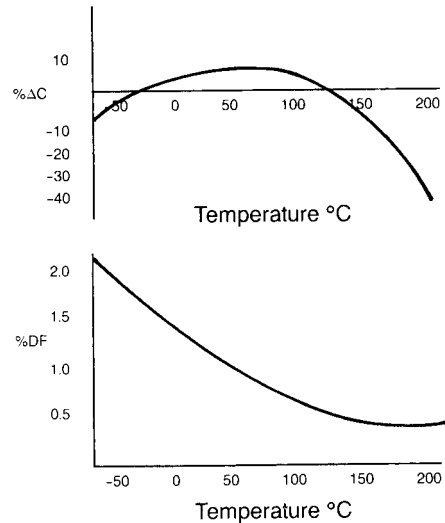

Figure 21

Product Options/Series

Glass Axial: CY, CYR, CYFR, ET & ETR Series

CY Series: Qualified to MIL-C-11272. Available in 4 case sizes; .5pF to 10,000pF; 500 VDC, 300 VDC rated, hermetically sealed.

CYR Series: Qualified to MIL-C-23269. Failure Rate Levels L, M, and S; available in 4 case sizes; .5pF to 10,000pF; 500 VDC, 300 VDC rated; 100 VDC (S level only); hermetically sealed.

CYFR Series: Meets or exceeds all requirements of AVX specifications J-950, J-951 (modeled after Minuteman high reliability specification); available in 4 case sizes; .5pF to 10,000pF; 500 VDC, 300 VDC rated. Insulation resistance greater than 500,000 megohms at 25°C, greater than 10,000 megohms at 125°C; hermetically sealed.

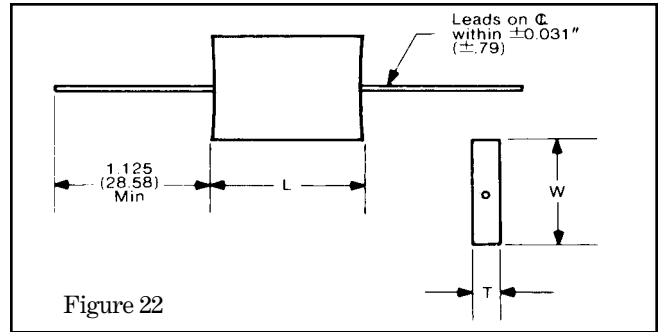

ET, ETR Series: Elevated Temperature (ETR High Reliability) series. Capable of operation over -75°C to +200°C with short overexposure to +250°C (≤1 hour). Available in 4 case sizes; .5pF to 10,000pF; 50 VDC rated across operating temperature range; hermetically sealed; ETR series burned-in at 1500 VDC, 50 hours, 25°C.

Table II
Capacitance Range/Case Sizes

Axial: CY, CYR, CYFR, ET & ETR Series

Dimensions: Inches (Millimeters)

Case Size	Capacitance Range	L	W	T	Lead Diameter +.004 (+0.1) -.001 (-0.03)	Weight (Grams)
10	.5pF to 300pF	.344 ± .047 (8.74 ± 1.19)	.172 ± .031 (4.37 ± .79)	.078 ± .031 (4.37 ± .79)	.020 (.51)	.25 - .50
15	220pF to 1200pF	.469 ± .047 (11.91 ± 1.19)	.266 ± .031 (6.76 ± .79)	.109 ± .047 (2.77 ± 1.19)	.020 (.51)	.75 - 1.25
20	560pF to 5100pF	.734 ± .062 (18.64 ± 1.57)	.422 ± .047 (10.72 ± 1.19)	.141 ± .047 (3.58 ± 1.19)	.025 (.63)	2.50 - 4.00
30	3600pF to 10,000pF	.766 ± .062 (19.46 ± 1.57)	.750 ± .078 (6.76 ± 1.98)	.141 ± .047 (3.58 ± 1.19)	.025 (.63)	5.00 - 7.00

Glass-K Axial: CK, CKR & ET Series

CK31, 32 Series: Qualified to MIL-C-11015/25; available in 2 case sizes, 3 temperature coefficients: BT, BU, BV; 270pF to .1μF; 50 VDC rated.

CKR31, 32 Series: Qualified to MIL-C-39014/21; Failure Rate Level M; available in 2 case sizes, 3 temperature coefficients: BT, BU, BV; 270pF to .1μF; 50 VDC rated.

ET31, 32 Series: Elevated Temperature series capable of operation over -75°C to +200°C; available in 2 case sizes, 3 temperature coefficients: K250, K380, K888; 270pF to .1μF; 25 VDC rated.

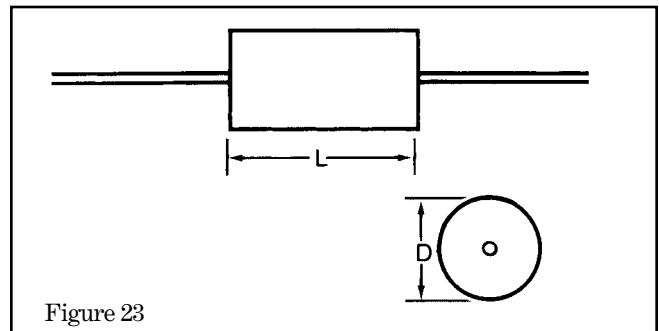

Table III
Capacitance Range/Case Sizes

Axial Glass-K CK, CKR & ET Series

Dimensions: Inches (Millimeters)

Case Size	Voltage Range	Length	Diameter	Lead Diameter +.004 (+0.1) -.001 (-0.03)	Weight (Grams)
31/2	270pF - 10,000pF	.240	.090	.016	.20
31/3	12,000pF - 20,000pF	.240	.090	(.41)	
31/8	22,000pF - 51,000pF	.240	.090		
32/2	12,000pF - 20,000pF	.240	.130	.016	.30
32/3	22,000pF - 37,000pF	.240	.130	(.41)	
32/8	56,000pF - 100,000pF	.240	.130		

Glass Radial: CY, CYR, ET & ETR Series

CY Series: Qualified to MIL-C-11272; available in 3 case sizes, 1pF to 2400pF; 300 VDC rated.

CYR Series: Qualified to MIL-C-23269; Failure Rate Levels L, M; available in 3 case sizes; 1pF to 2400pF.

ET, ETR Series: Elevated Temperature (ETR High Reliability) series capable of operation over -75°C to +200°C. Available in 3 case sizes; 1pF to 2400pF; 50 VDC rated across operating temperature range. ETR series burned-in at 1500 VDC, 50 hours, 25°C.

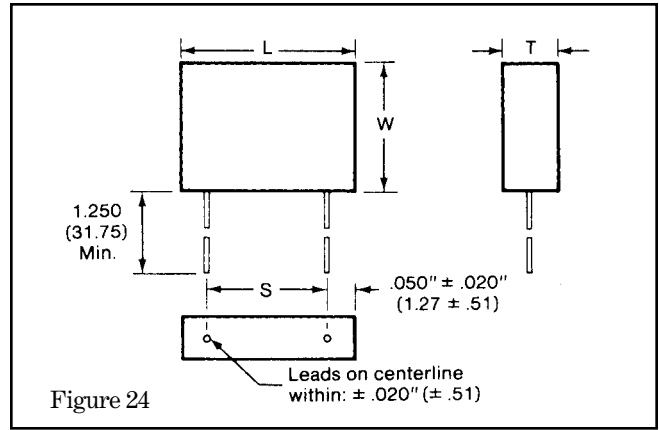

Table IV
Capacitance Range/Case Sizes

Radial: CY, CYR, ET & ETR Series

Dimensions: Inches (Millimeters)

Case Size	Capacitance Range	L ±.005 (±.13)	W ±.010 (±.25)	T ±.005 (±.13)	Lead Diameter ±.002 (±.051)	S ±.020 (±.51)	Weight (Grams)
06/51	1pF to 560pF	.300 (7.62)	.200 (5.08)	.115 (2.92)	.020 (.51)	.200 (5.08)	.3 - .4
07/52	620pF to 1000pF	.300 (7.62)	.300 (7.62)	.115 (2.92)	.020 (.51)	.200 (5.08)	.4 - .5
08/53	1100pF to 2400pF	.500 (12.70)	.300 (7.62)	.115 (2.92)	.020 (.51)	.400 (10.16)	.7 - .8

NOTICE: Specifications are subject to change without notice. Contact your nearest AVX Sales Office for the latest specifications. All statements, information and data given herein are believed to be accurate and reliable, but are presented without guarantee, warranty, or responsibility of any kind, expressed or implied. Statements or suggestions concerning possible use of our products are made without representation or warranty that any such use is free of patent infringement and are not recommendations to infringe any patent. The user should not assume that all safety measures are indicated or that other measures may not be required. Specifications are typical and may not apply to all applications.

USA

AVX Myrtle Beach, SC Corporate Offices

Tel: 843-448-9411
FAX: 843-626-5292

AVX Northwest, WA

Tel: 360-699-8746
FAX: 360-699-8751

AVX North Central, IN

Tel: 317-848-7153
FAX: 317-844-9314

AVX Mid/Pacific, MN

Tel: 952-974-9155
FAX: 952-974-9179

AVX Southwest, AZ

Tel: 480-539-1496
FAX: 480-539-1501

AVX South Central, TX

Tel: 972-669-1223
FAX: 972-669-2090

AVX Southeast, NC

Tel: 919-878-6223
FAX: 919-878-6462

AVX Canada

Tel: 905-564-8959
FAX: 905-564-9728

EUROPE

AVX Limited, England European Headquarters

Tel: ++44 (0) 1252 770000
FAX: ++44 (0) 1252 770001

AVX S.A., France

Tel: ++33 (1) 69.18.46.00
FAX: ++33 (1) 69.28.73.87

AVX GmbH, Germany - AVX

Tel: ++49 (0) 8131 9004-0
FAX: ++49 (0) 8131 9004-44

AVX GmbH, Germany - Elco

Tel: ++49 (0) 2741 2990
FAX: ++49 (0) 2741 299133

AVX srl, Italy

Tel: ++390 (0)2 614571
FAX: ++390 (0)2 614 2576

AVX Czech Republic, s.r.o.

Tel: ++420 (0)467 558340
FAX: ++420 (0)467 558345

ASIA-PACIFIC

AVX/Kyocera, Singapore Asia-Pacific Headquarters

Tel: (65) 258-2833
FAX: (65) 350-4880

AVX/Kyocera, Hong Kong

Tel: (852) 2-363-3303
FAX: (852) 2-765-8185

AVX/Kyocera, Korea

Tel: (82) 2-785-6504
FAX: (82) 2-784-5411

AVX/Kyocera, Taiwan

Tel: (886) 2-2696-4636
FAX: (886) 2-2696-4237

AVX/Kyocera, China

Tel: (86) 21-6249-0314-16
FAX: (86) 21-6249-0313

AVX/Kyocera, Malaysia

Tel: (60) 4-228-1190
FAX: (60) 4-228-1196

Elco, Japan

Tel: 045-943-2906/7
FAX: 045-943-2910

Kyocera, Japan - AVX

Tel: (81) 75-604-3426
FAX: (81) 75-604-3425

Kyocera, Japan - KDP

Tel: (81) 75-604-3424
FAX: (81) 75-604-3425

Contact:



<http://www.avxcorp.com>

S-PGDC00M0401-R