

---

## Getting Started Guide

# Getting started with iCONNECT for LabVIEW

This *Getting Started Guide* assumes you are familiar with both National Instruments LabVIEW and iSYSTEM emulators and winIDEA IDE.

## Concept

iCONNECT for LabVIEW includes a library of VIs to link LabVIEW graphical programming environment to winIDEA. It provides the user with means to interact with the program running on an embedded CPU.

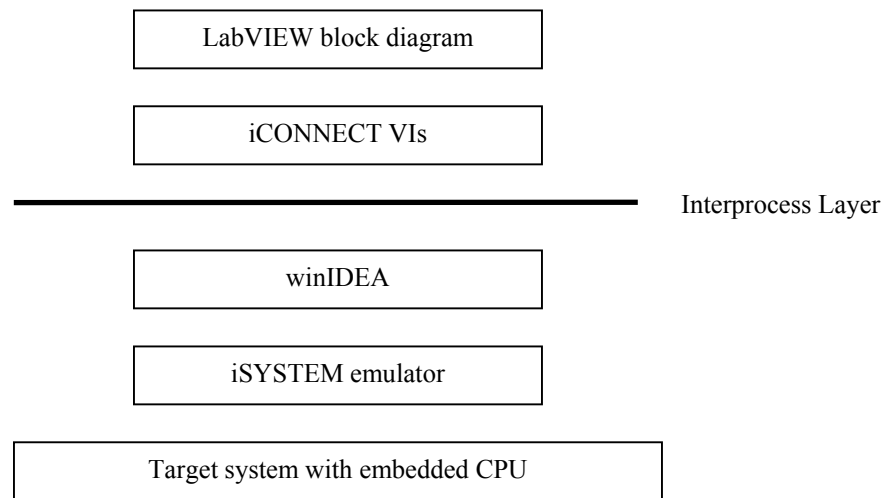

iCONNECT set of VIs will connect to the winIDEA through a TCP/IP based interprocess layer which allows LabVIEW to run on a different host PC than winIDEA.

## System Requirements

iCONNECT for LabVIEW requires:

- winIDEA 2005 (build 9.5.61 or later)
- LabVIEW 7.1 or later

---

Note: iCONNECT for LabVIEW must be installed on the PC where LabVIEW is installed.

---

## Configuring winIDEA

Before you start using iCONNECT VIs in LabVIEW, make sure a winIDEA workspace is properly configured for your target application. Connect the emulator to the target system and verify that your application is running properly under emulator control.

See also winIDEA user manual about setting up the debugging environment.

# Using iCONNECT in LabVIEW

The following section demonstrates how to create an application that will display the value of a target application variable.

1. Create a new blank VI in LabVIEW and switch to block diagram. The iCONNECT VIs can be found under User Libraries function palette in block diagram.

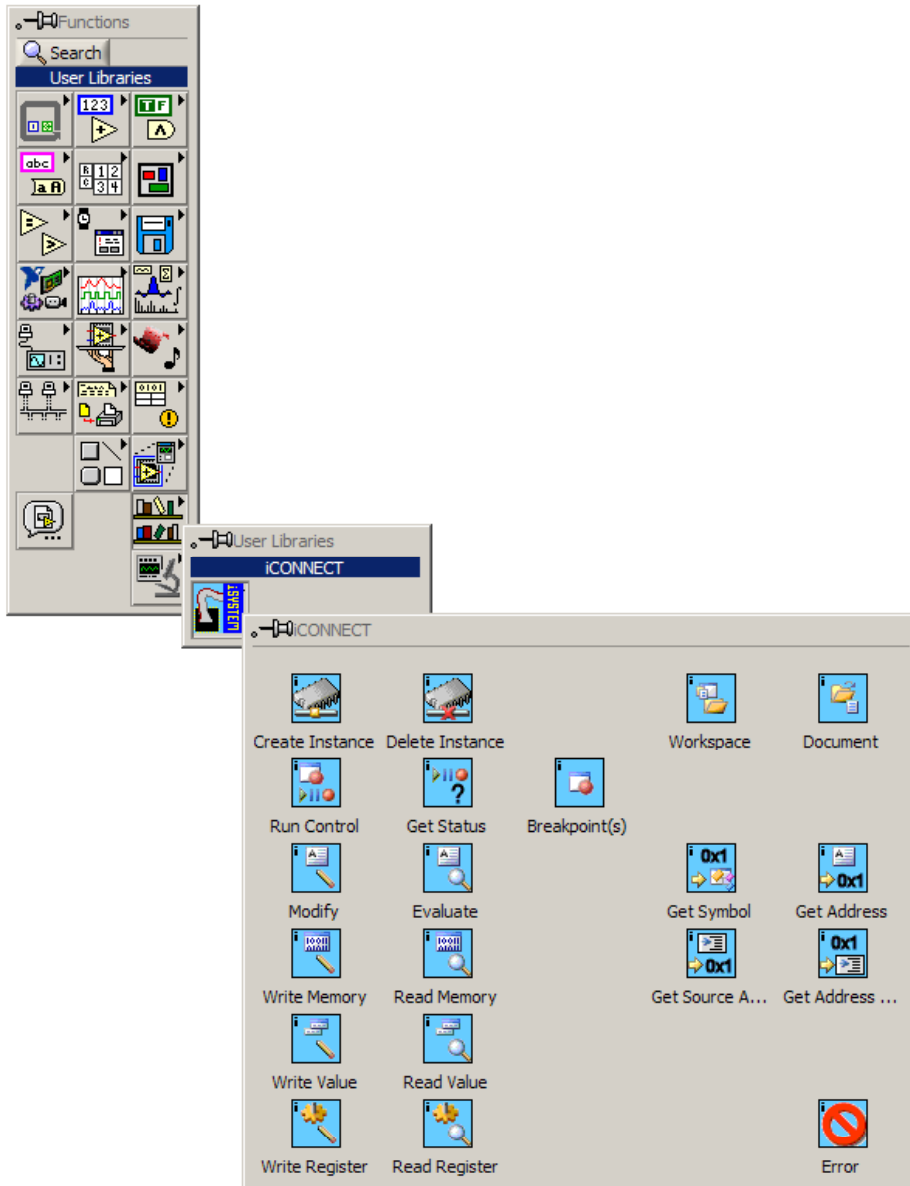

2. Create a front panel diagram as shown below.

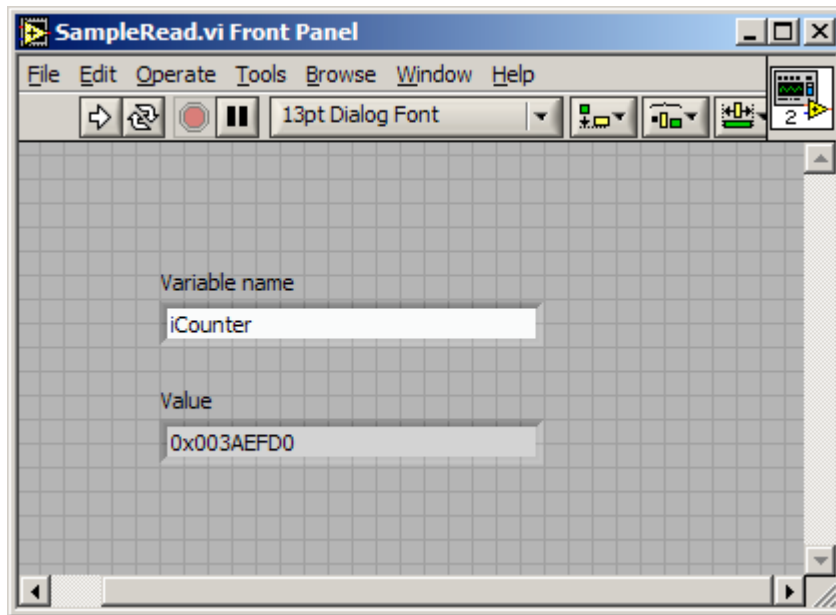

3. Create the following block diagram

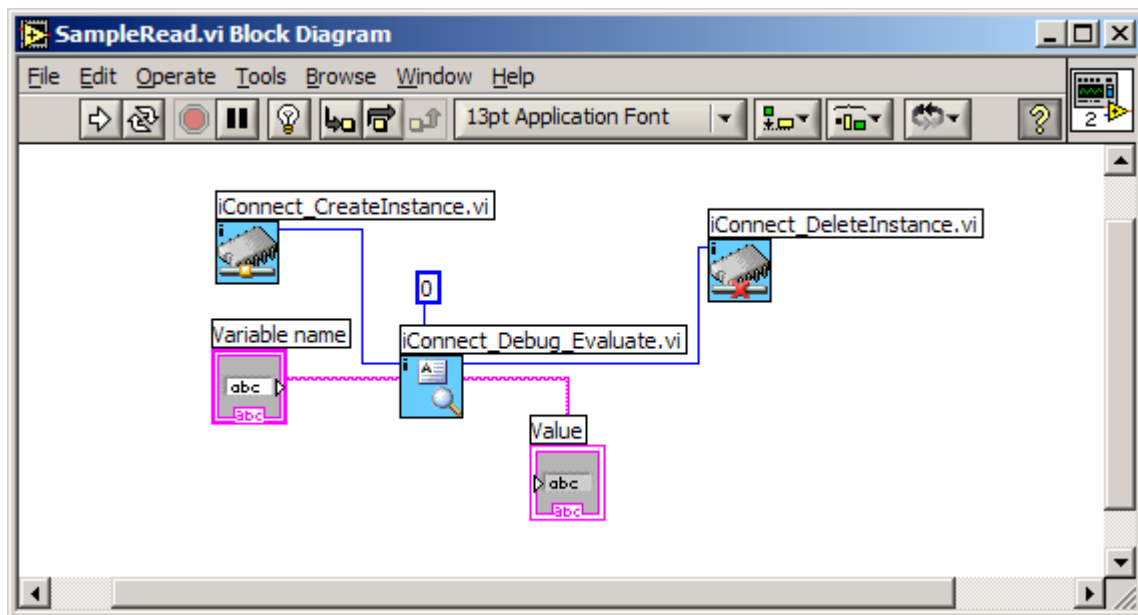

4. Make sure winIDEA is running and the program has been downloaded to the target.
5. Run the SampleRead VI.

## iCONNECT VI Rules

iCONNECT VIs follow common LabVIEW design guidelines. In addition to these, the following rules must be observed:

- Use **iConnect\_CreateInstance.vi** to connect to winIDEA. Output of this VI is an instance handle that must be subsequently wired to each iCONNECT VI used.
- Use **iConnect\_DeleteInstance.vi** to disconnect from winIDEA.
- Call **iConnect\_CreateInstance.vi** only once in your application if you are connecting to a single winIDEA instance. Multiple winIDEA instances can be controlled via multiple **iConnect\_CreateInstance.vi** calls.

The below block diagram shows an example that reads a variable and then resets it to zero:

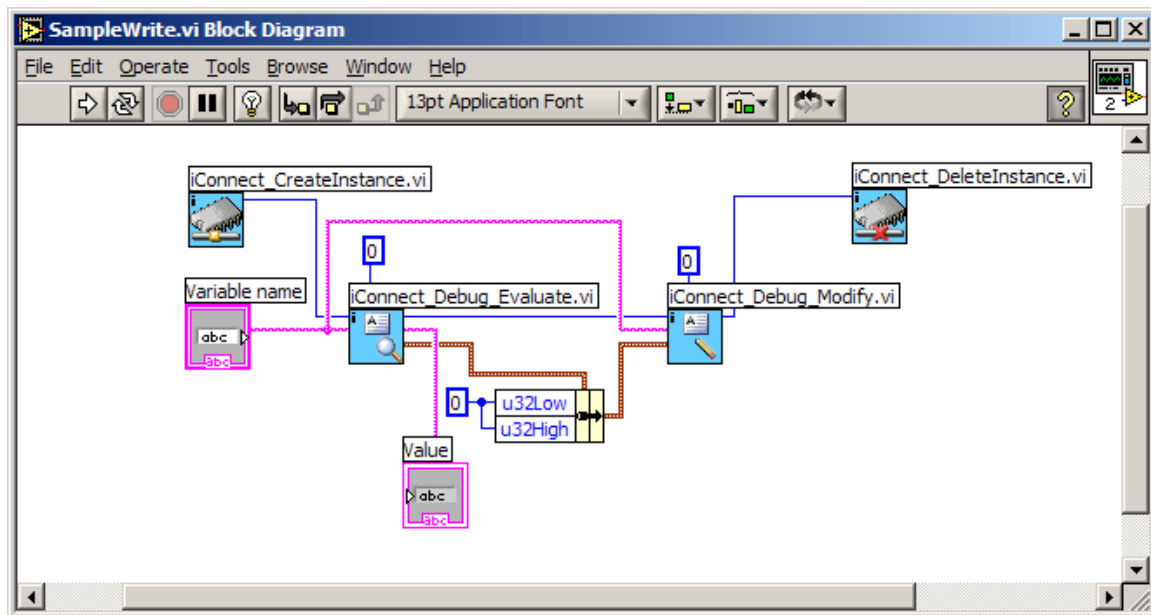

---

Note: iCONNECT VIs provide additional information in the LabVIEW context help.

---

## Troubleshooting

If a connection to winIDEA can not be established, check whether the iCONNECT interface has been disabled.

In winIDEA open the Tools/Options/iCONNECT dialog and make sure the iCONNECT interface is enabled.

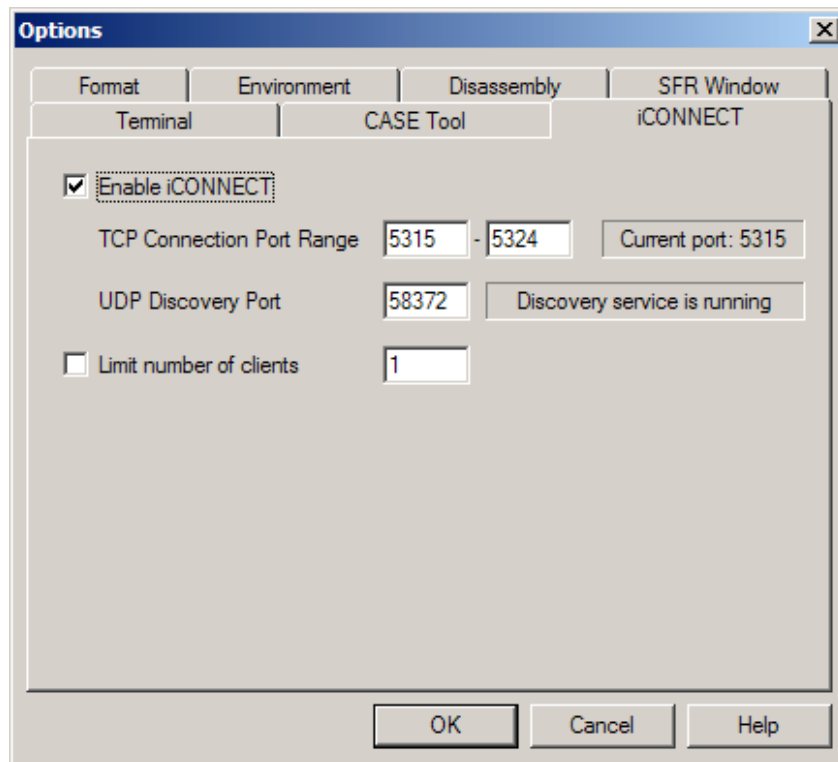

---

Note: This is a **per-user** setting. Once enabled, you can connect to winIDEA independently of the workspace used.

---

The iCONNECT interprocess communication layer relies on the TCP/IP protocol. While this protocol allows great flexibility, many systems and network configurations block all but the most common TCP ports for security reasons.

**TCP Connection Port Range** specifies the range of TCP ports on which winIDEA will try to establish the iCONNECT service. If you are running multiple instances of winIDEA, every winIDEA will use one TCP port. The default port values should work fine – if this is not the case, check any firewall setting that might affect the host PC.

**UDP Discovery Port** specifies a UDP port on which all running instances of winIDEA will respond to broadcast queries. Same firewall restrictions as for TCP ports apply here.

**Limit number of clients** allows for limitation of allowed clients on a single winIDEA instance. If multiple clients are connected to winIDEA, their actions might conflict and/or result in lower response time. Note that unlike other settings in this dialog, this is a **per-workspace** setting.